



Thermo Scientific F1-ClipTip Single Channel Multichannel

Instructions for Use

This product complies with the European Union Directive 98/79/EC, and it is marked with a CE marking.

When the product is used in applications related to the Directive 98/79/EC, read the additional information enclosed in the product package or contact the manufacturer at **info.pipettes@thermofisher.com** to ensure correct and safe use.

The CE mark covers the system containing the CE marked F1-ClipTip pipette and the CE marked ClipTip pipette tips.

Product specifications are subject to change without prior notice. ClipTip is a registered trademark of Thermo Fisher Scientific Inc. and its subsidiaries.

CONTENTS

1. INTRODUCTION	4
2. PACKAGE	5
3. MAIN ILLUSTRATION	5
4. SAFETY	6
5. OPERATION	7
6. CALIBRATION AND ADJUSTMENT	9
7. MAINTENANCE	11
8. STERILIZATION	16
9. TROUBLESHOOTING	17
10. APPENDICES	18

1. Introduction

Congratulations on your purchase of a Thermo Scientific® F1-ClipTip® pipette!

The F1-ClipTip is a general purpose air displacement micropipette. Its intended use is for aspirating and dispensing liquids.

The F1-ClipTip features an innovative interlocking tip interface technology that locks the tip in place ensuring secure tip attachment and preventing tips from being displaced in the middle of pipetting. F1-ClipTip operates only with ClipTip® tips. For improved ergonomics, tips are attached and ejected using minimal application pressure.

The F1-ClipTip product offering covers a volume range from 1 µl to 1000 µl and includes variable and fixed volume single channel pipettes as well as multichannel pipettes. The convenient color coding* system facilitates to identify the correct ClipTip by volume for use.

F1-ClipTip Variable Volume Single Channel

Cat. no.	Description	Volume range	Increment	Color code	Compatible ClipTip
4641170N	F1-ClipTip 1-10 µl	1–10 µl	0.02 µl	pink	ClipTip 20
4641180N	F1-ClipTip 2-20 µl	2–20 µl	0.02 µl	pink	ClipTip 20
4641190N	F1-ClipTip 5-50 µl	5–50 µl	0.1 µl	violet	ClipTip 50
4641200N	F1-ClipTip 10-100 µl	10–100 µl	0.2 µl	yellow	ClipTip 200
4641210N	F1-ClipTip 20-200 µl	20–200 µl	0.2 µl	yellow	ClipTip 200
4641220N	F1-ClipTip 30-300 µl	30–300 µl	1 µl	orange	ClipTip 300
4641230N	F1-ClipTip 100-1000 µl	100–1000 µl	1 µl	blue	ClipTip 1000

F1-ClipTip Fixed Volume Single Channel

Cat. no.	Description	Volume range	Color code	Compatible ClipTip
4651190N	F1-ClipTip 10 µl	10 µl	dark blue	ClipTip 20
4651200N	F1-ClipTip 20 µl	20 µl	dark blue	ClipTip 50
4651210N	F1-ClipTip 25 µl	25 µl	dark blue	ClipTip 50
4651220N	F1-ClipTip 50 µl	50 µl	dark blue	ClipTip 50
4651230N	F1-ClipTip 100 µl	100 µl	dark blue	ClipTip 200
4651240N	F1-ClipTip 200 µl	200 µl	dark blue	ClipTip 200
4651250N	F1-ClipTip 250 µl	250 µl	dark blue	ClipTip 300
4651260N	F1-ClipTip 500 µl	500 µl	dark blue	ClipTip 1000
4651270N	F1-ClipTip 1000 µl	1000 µl	dark blue	ClipTip 1000

* color coding does not apply to fixed models

F1-ClipTip Multichannel

Cat. no.	Description	Channels	Volume range	Increment	Color code	Compatible ClipTip
4661110N	F1-ClipTip 8-ch 1–10 µl	8	1–10 µl	0.02 µl	pink	ClipTip 20
4661120N	F1-ClipTip 8-ch 5–50 µl	8	5–50 µl	0.1 µl	violet	ClipTip 50
4661130N	F1-ClipTip 8-ch 10–100 µl	8	10–100 µl	0.2 µl	yellow	ClipTip 200
4661140N	F1-ClipTip 8-ch 30–300 µl	8	30–300 µl	1 µl	orange	ClipTip 300
4661150N	F1-ClipTip 12-ch 1–10 µl	12	1–10 µl	0.02 µl	pink	ClipTip 20
4661160N	F1-ClipTip 12-ch 5–50 µl	12	5–50 µl	0.1 µl	violet	ClipTip 50
4661170N	F1-ClipTip 12-ch 10–100 µl	12	10–100 µl	0.2 µl	yellow	ClipTip 200
4661180N	F1-ClipTip 12-ch 30–300 µl	12	30–300 µl	1 µl	orange	ClipTip 300

2. Package

The F1-ClipTip package contains the following items:

1. F1-ClipTip pipette
2. Service tool
3. Multichannel service tool
4. Tip fitting tool
5. ClipTip tip sample
6. Tube of grease (Order No. 2203130)
7. *Instructions for Use*
8. Calibration certificate / Warranty Certificate
9. Shelf hanger (Order No. 2206040)
10. Warning labels
11. O-ring Order No. 2214930 Single Channel Pipette (Scp) 300 (3 pcs)
 Order No. 2215540 Scp 1000 (3 pcs)
 Order No. 2214920 Multichannel Pipette (Mcp) (12 pcs)

3. Main Illustration

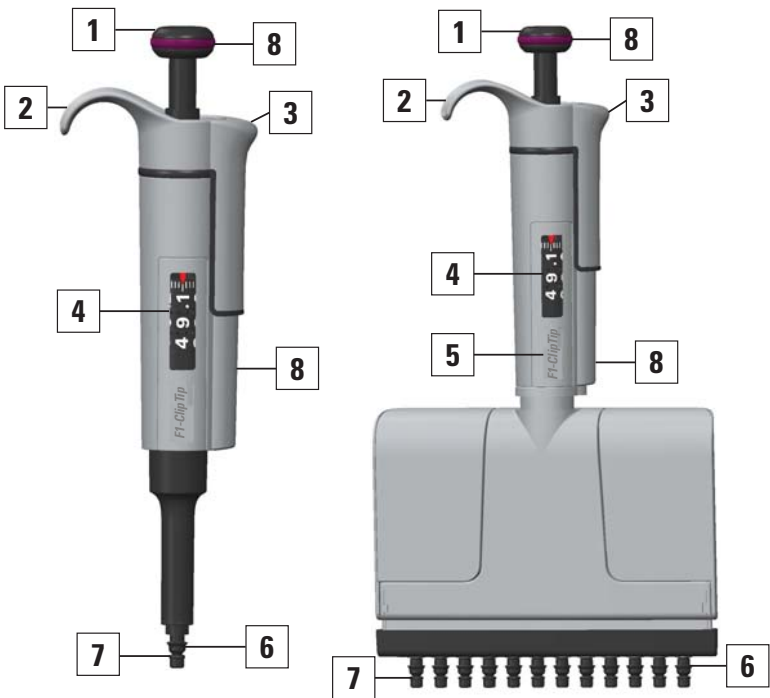

- 1 *Pipetting and volume adjustment button*
- 2 *Adjustable finger rest*
- 3 *Tip ejector*
- 4 *Volume display*
- 5 *Space for personal ID tag*
- 6 *Tip fitting*
- 7 *Tip sealing O-ring*
- 8 *Color coding*

3.1. Materials

The F1-ClipTip is made of mechanically durable and chemically resistant materials. For waste disposal instructions, contact your local environmental agency. For more information, contact us at info.pipettes@thermofisher.com.

 Aggressive substances can damage the pipette or pipette parts. Check for material compatibility before using organic solvents and aggressive chemicals.

ClipTip pipette tips are made of natural color virgin polypropylene. The tips feature a hydrophobic surface, which effectively prevents liquid retention. ClipTips pipette tips come in multiple packaging options including racks and reload packs, in sterile and non-sterile versions. ClipTip tips are also available with a filter and are certified free of human DNA, RNase, DNase, ATP and endotoxin contamination.

The material used in F1-ClipTip pipettes and ClipTip tips are as follows:

F1-CLIPTIP PIPETTES		
Material		
External surfaces of the upper parts:		
ABS/PC		acrylonitrilebutadienstyrene/polycarbonate
PA		polyamide
PEI		polyetherimide
Foil		
Exterior and interior of lower parts:		
PEI		polyetherimide
PA		polyamide
PVDF		polyvinylidenfluoride
EPDM		ethylene-propylene-diene rubber
FVM		fluorosilicone rubber
Steel		stainless steel
PPSU		Polyphenylsulfone
CLIPTIP TIPS		
Tip	PP	polypropylene
Filters	PE	polyethylene

4. Safety

Cautions are marked with this symbol .

4.1. Intended use

The intended use of the device is to transfer liquids in the volume range of 1 µl to 1000 µl. The F1-ClipTip pipette and ClipTip tip are designed as a component of an analyzing system for an end user, who is responsible for validating the system to ensure reliable and safe results.

Damage to health

- ▶ Follow general procedures for hazard prevention and safety instructions; e.g. wear protective clothing, eye protection and gloves.
- ▶ For use and waste disposal of hazardous (e.g. radioactive and potentially infectious) material, follow the safety instructions and general laboratory practice.
- ▶ The pipette and tips are not intended for in vivo use. Do not use the pipette for pipetting any liquid to be injected into a human body.
- ▶ Do not eject the tip towards anybody.

The F1-ClipTip is to be used by trained personnel with required laboratory skills. The instructions for use must be read prior to and during the use of the device (pipette and tip). The F1-ClipTip pipette can be used between +4°C and +40°C.



Incorrect dispensing results

- ▶ Performance may vary due to:
 - a. pipetting method (forward pipetting technique recommended)
 - b. temperature (air, liquid, vessel, pipette, and tip)
 - c. pressure
 - d. humidity
 - e. operator, e.g. thumb movement, pipetting angle
 - f. liquid density, viscosity and vapor pressure
 - g. type of tip
- ▶ If the pipetting performance is critical to the outcome of a specific application, the result has to be assured with an alternative test, and if this is not an option, by duplicate testing. The possibility of an incorrect volume delivery during pipetting cannot be entirely mitigated.
- ▶ To avoid inaccurate dispensing and/or leakage, check that the tip is properly attached to the pipette.
- ▶ When rotating the volume adjustment button, do not exceed the volume range of the pipette. Otherwise the pipette may be damaged or affect pipetting performance.
- ▶ Pipetting performance cannot be guaranteed if the tip is reused.
- ▶ Choose only a tip and pipette with matching color coding.

5. Operation



Cautions for incorrect operation

- ▶ For optimum performance, make sure that the tips, pipette and solution are at the same temperature.
- ▶ Before you begin your actual pipetting, fill and empty the tip three to five times with the solution that you will be pipetting.
- ▶ Push and release the pipetting button slowly at all times particularly when working with high viscosity liquids. Never allow the pipetting button to snap back.
- ▶ Do not hold the pipette horizontally or upside down when there is liquid inside the tip. Sample liquid may enter the pipette, which will affect the pipetting performance and may damage the pipette.
- ▶ Operate the pipetting button gently. If it is quickly released, sample liquid may enter the pipette, which will affect the pipetting performance and may damage the pipette.
- ▶ Follow the ergonomic guidelines for laboratory work to minimize the risk of repetitive strain injury (RSI).

5.1 ID-tag

You can mark the pipette ID-tag with your initials, pipetting application or calibration date. Remove the pipette's module to replace the tag. Mark the label and slide the tag together with the holder back to its slot (Picture 1).

5.2 Adjusting the finger rest

The finger rest supports the position of the pipette on the index finger, enhancing ergonomics. The finger rest can be adjusted by rotating it 60 degrees in both directions from the center position (Picture 2). Usually right-handed operators turn it left (counter clockwise) to achieve the best possible position for the thumb to eject the tip.

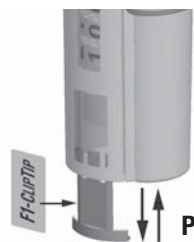

Picture 1



Picture 2

5.3 Setting the delivery volume

1. Set the delivery volume using the volume adjustment button on the top of the pipette (Picture 3). Pull the button to activate the volume setting.
2. To increase the delivery volume, turn the button counterclockwise. To decrease the delivery volume, turn it clockwise.
3. Lock the volume by pushing the button down.
4. Check the volume on the display.

NOTE! Do not set volumes outside the pipette's specified volume range. Using excessive force to turn the volume adjustment button outside the range may jam the mechanism and eventually damage the pipette.



Picture 3

5.4 Tip attachment

1. To attach the tip, guide the pipette into a ClipTip in a rack and press with light force until the tip is attached. A delicate click sound will indicate that the tip is attached. The tip is attached when the clips* (Picture 4) are locked to the tip fitting. Do not use excessive force when attaching the tips as the device requires minimum attachment force.
2. Lift the pipette.
3. If the tip is not attached, repeat Steps 1 and 2.



Incorrect use of tips

- ▶ Use only ClipTip tips with an F1-ClipTip pipette.
- ▶ Check that all clips are locked to ensure tip sealing.
- ▶ ClipTip tips are designed for single use only.
- ▶ To ensure sterility and purity of tips check that the package is unbroken. For sterile tips also ensure that the indicator dot is red.
- ▶ Check that the tip is complete and unbroken. Check for foreign particles in the tip.
- ▶ Check that the filter tips have filters in place and that each filter is unbroken and not tilted.

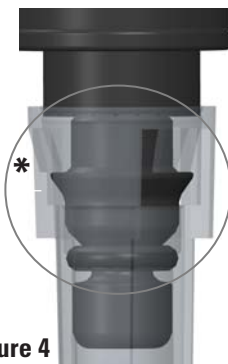

Picture 4

5.5 Aspirating and dispensing liquid

1. Fill a suitable vessel with the liquid to be dispensed.
2. Depress the pipetting button to the first stop (Picture 5).
3. Dip the tip under the surface of the liquid in the reservoir to a depth of about 1 cm and slowly release the button. Withdraw the tip from the liquid by moving it against the edge of the reservoir to remove excess liquid.
4. Deliver the liquid by gently depressing the button to the first stop. After a delay of about one second, continue to depress the button all the way to the second stop. This action will empty the tip.
5. Withdraw the tip by moving it against the edge of the target container.

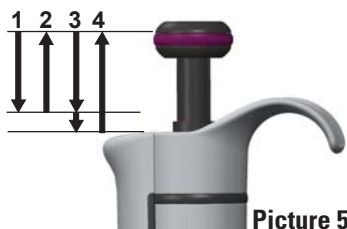

Picture 5

Ensure proper functioning of F1-ClipTip 1-10µl multichannel and 1-50 µl single channel pipettes

The F1-ClipTip 1-10µl multichannel and 1-50 µl single channel pipettes utilize an innovative super blow-out piston technology to ensure efficient liquid delivery with small volumes. In pipettes with the super blow-out piston three separate movements are observed (Picture 6) when the plunger is pressed down to dispense liquid:

1. Primary plunger movement – delivers the set volume amount
2. Blow-out – additional phase to dispense residual liquid
3. Super blow-out – enhances the effectiveness of blow-out

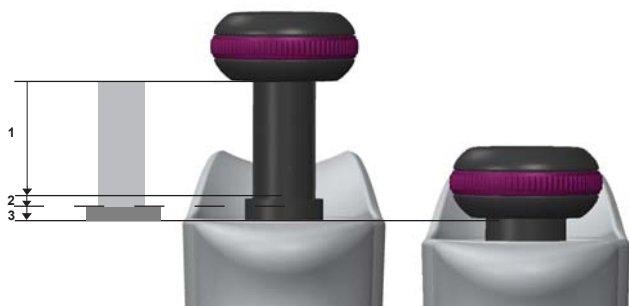

Picture 6

Plunger in up position

Plunger in down position

When the pipette is not used for a period of time, the plunger movement may become stiff due to hardening of grease. In rare cases this can affect the functionality of the super blow-out piston, which can become temporarily jammed. To ensure proper functionality it is recommended to press the plunger several times to the final stop (step 3 in picture) before dosing the sample liquid. This releases the piston and re-distributes the lubricant.

NOTE! If the super blow-out piston is jammed, increased force might be required to release it. Ensure that plunger moves to the down position (Picture 6).

For more information about different pipetting techniques, check the **Good Laboratory Pipetting Guide** online.

5.6 Tip ejection

To release the tip, point the pipette at a suitable waste receptacle and press the tip ejector with your thumb.

6. Calibration and Adjustment

6.1 Factory calibration limits

F1-ClipTip pipettes are factory calibrated and adjusted to give the volumes as specified with distilled or deionized water using the forward pipetting technique. Manufacturer specifications are shown on the pipette calibration certificate and in Appendix 2.



Cautions for calibration and pipette adjustment

- ▶ It should be noted that the use of different pipetting techniques may affect the calibration results. The pipettes are constructed to permit re-adjustment for other pipetting techniques or liquids of different temperature and viscosity.
- ▶ The performance of a new and serviced pipette must be checked and documented.
- ▶ The manufacturer's specifications should be used as guidelines and the user should establish acceptable imprecision and inaccuracy performance limits (ISO 8655).
- ▶ The user determines the performance and applicability of the pipette and tip combination for a particular application and determine the required interval for performance checking.
- ▶ Before starting the actual dosing, pre-rinse the tip with the liquid by filling and emptying the tip three to five times to improve accuracy and precision.

6.2 Test conditions and equipment

An analytical balance must be used. The scale graduation value of the balance should be chosen according to the selected test volume of the pipette:

Volume range	Readable graduation
under 10 μl	0.001 mg
10–100 μl	0.01 mg
above 100 μl	0.1 mg

The test liquid is deionized distilled "grade 3" water in compliance with ISO 3696. Tests are done in a draft-free room at a constant ($\pm 0.5^\circ\text{C}$) temperature between 15°C to 30°C . The relative humidity must be above 50%. Especially with volumes under 50 μl , air humidity should be as high as possible to reduce the effect of evaporation loss. Special accessories, such as an evaporation trap, are recommended.

6.3 Procedure to check calibration

The pipette is checked at maximum volume (nominal volume) and minimum volume. A new tip is first pre-wetted three to five times and a series of ten pipettings is done at both volumes. A pipette is always adjusted according to the delivery of the selected volume. Use of the forward pipetting technique is recommended. The maximum permissible errors are valid for the forward pipetting method. It is recommended to use the ISO8655 calibration limits in Appendix 3 or user-defined specifications.

Procedure:

1. Do 10 pipettings at the minimum volume.
2. Do 10 pipettings at the maximum volume.
3. Calculate the inaccuracy (A) and imprecision (CV) of both series.
4. Compare the results to the limits.

If the calculated results are within the selected limits, the adjustment of the pipette is correct.

Pipette adjustment

Adjustment is done only for one volume. The recommended adjustment volume is the minimum volume or 10% of the maximum volume.

1. Fit the service tool (Picture 7) into the openings of the calibration nut at the top of the handle.
2. Turn the service tool clockwise to increase, or counterclockwise to decrease the volume.
3. After adjustment, check the calibration according to the instructions above.

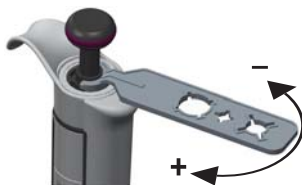

Picture 7

Formulas for calculating results

Conversion of mass to volume

$$V = (w + e) \times Z$$

V = volume (μl)
 w = weight (mg)
 e = evaporation loss (mg)
 Z = conversion factor for $\mu\text{l}/\text{mg}$ conversion

Evaporation loss can be significant at low volumes. To determine mass loss, dispense water into the weighing vessel, note the reading and start a stopwatch. Check and note down how much the reading decreases during 30 seconds (e.g. $6 \text{ mg} = 0.2 \text{ mg/s}$).

Compare this to the pipetting time from taring to reading. Typically, the pipetting time might be 10 seconds and the mass loss is then 2 mg ($10 \text{ s} \times 0.2 \text{ mg/s}$ in this example). If an evaporation trap or lid on the vessel is used, the correction of evaporation is usually unnecessary.

The factor Z is for converting the weight of the water to volume at the test temperature and pressure. A typical value is $1.0032 \mu\text{l}/\text{mg}$ at 22°C and 95 kPa . See the conversion table in Appendix 1.

Inaccuracy (systematic error)

Inaccuracy is the difference between the dispensed volume and the selected volume of a pipette.

$$A = \bar{V} - V_0$$

A = inaccuracy
 \bar{V} = mean volume
 V_0 = nominal volume

Inaccuracy can be expressed as a relative value: $A\% = 100\% \times A / V_0$

Imprecision (random error)

Imprecision refers to the repeatability of the pipettings. It is expressed as standard deviation (S) or coefficient of variation (CV)

$$S = \sqrt{\frac{\sum_{i=1}^n (V_i - \bar{V})^2}{n-1}}$$

S = standards deviation
 \bar{V} = mean volume
 n = number of measurements

Standard deviation can be expressed as a relative value: $CV = 100\% \times S / \bar{V}$

7. Maintenance



Cautions for incorrect maintenance

- ▶ The pipette should be regularly serviced according to the instructions for use.
- ▶ The pipette performance and functioning must be checked after maintenance.
- ▶ Aggressive substances can damage the pipette or pipette parts. Check for material compatibility before using organic solvents and aggressive chemicals.
- ▶ Use only original Thermo Scientific spare parts and ClipTip tips.
- ▶ Avoid excess grease. Use only the grease provided with the pipette.
- ▶ If the pipette is used daily, it is recommended to service the pipette every three months.
- ▶ When the F1-ClipTip is not in use, make sure it is stored in an upright position. We recommend a pipette stand for this purpose.
- ▶ When shipping the device for service or inspection, ensure that it is completely free of chemical, biological, or radioactive contamination.

7.1 Daily maintenance

The pipette should be checked at the beginning of each day for dust and dirt on its outside surfaces. Particular attention should be paid to the tip cone. To clean the pipette, we recommend wiping it with a napless cloth wetted with 70% ethanol.

Leakage test

A leakage test can be performed at any time. It is recommended to be carried out after maintenance or autoclaving.

- ▶ Pre-wet the tip three to five times with water.
- ▶ Aspirate a nominal volume of water into the tip.
- ▶ Place the pipette on a stand or keep it firmly in your hand.
- ▶ Wait for 20 seconds.
- ▶ If a drop falls within 20 s, the pipette is leaking.

If the pipette leaks, see Chapter 9: "Troubleshooting" for possible reasons and solutions.

7.2 Periodic maintenance

The maintenance procedure starts with the disassembly of the pipette.



F1-ClipTip O-rings 5.1 are wearing parts. It is recommended to replace O-rings regularly to ensure proper sealing. Always replace the O-rings if they are worn or damaged.

7.2.1 Disassembly of 1000ul single channel pipettes

1. Remove the tip fitting 5 (Picture 8).
To remove the tip fitting place the star-shaped end of tool 3 (picture 9) into the end of the tip fitting. Turn the tool counterclockwise to unscrew the tip fitting (picture 10).

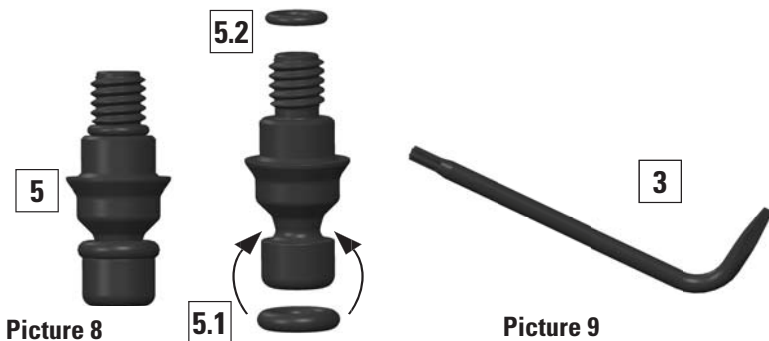

2. Press the tip ejector 4.1. Rotate the tip ejector 10 counterclockwise and pull it out (Picture 11).
3. Turn the tip cone 11 counterclockwise with the service tool 1. There are two slots in the service tool: the smaller one for pipettes under 300 μl and the bigger one for pipettes over 300 μl .
4. Pull out the piston assembly and other parts from the handle with the tip cone 11. Then turn the tip cone upside down and tap all parts from it.

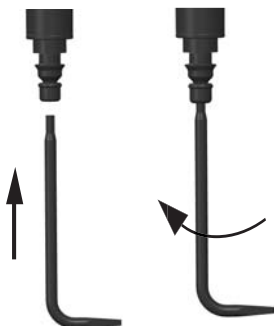

Picture 10

7.2.2 Disassembly of single channel pipettes 300ul and smaller

1. Press the tip ejector 4.1. Rotate the tip ejector 10 counterclockwise and pull it out (Picture 12).

NOTE! If you want to service only parts inside cylinder go to step 4. But then use the bigger slot in service tool.

2. Remove the tip fitting 5 (Picture 8). To remove the tip fitting place the star-shaped end of tool 3 (picture 9) into the end of the tip fitting. Pull the Clip trigger 8 backwards slightly with the other hand. Turn the tool counterclockwise to unscrew the tip fitting (picture 10).
3. Remove the Clip trigger 8 and Clip trigger spring 9.
4. Turn the tip cone 11 counterclockwise with the service tool 1. There are two slots in the service tool: the smaller one for pipettes under 300 μl and the bigger one for pipettes over 300 μl .
5. Pull out the piston assembly and other parts from the handle with the tip cone 11.

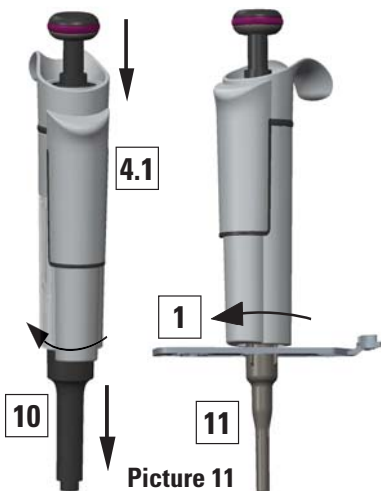

Picture 11

5. Pull out the piston assembly and other parts from the handle with the tip cone 11. Then turn the tip cone upside down and tap all parts from it.

You can check the parts of each specific pipette from the pictures starting on page 23.

Remember to keep all parts in order on the table for reassembly.

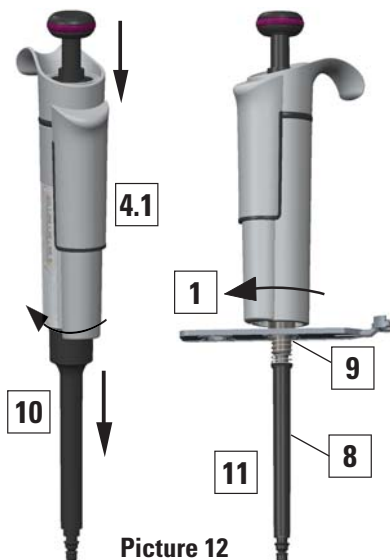

Picture 12

7.2.3 Cleaning and reassembling single channel pipettes

- General maintenance instructions can be found on page 11.
- Clean the piston, the piston spring and the O-rings with a dry napless cloth.
- Check the tip cone for foreign particles or dirt. Immerse it in a suitable cleaning solution. Dry before assembly.
- Grease the cleaned parts with the lubricant that comes with the pipette.
- The pipette is assembled in the reverse order to disassembling. Check the volume-specific reassembling of the piston assemblies starting on page 23.

Piston reassembly procedures

1-10 μ l, 10 μ l Fixed

- First slide the spring 21, O-ring support 22 and O-ring 23 onto the tube 20.
- Then slide the spring 13, the spring support 16 and tube 17, the bigger O-ring 18 and the smaller O-ring 19 back onto the piston 12.
- Compress the spring 13 with your fingers by pressing the piston and the spring support 16 against each other, and then slide the tube 20 with the remaining parts onto the piston.
- Hold the spring 13 compressed and carefully slide the entire assembly into the tip cone 11, and then release the spring.
- Put the spring 15 and support 14 on top of the tip cone and carefully insert the tip cone assembly to the handle. Attach the tip cone by turning it first clockwise tight by hand, then do the final tightening with the service tool.
- Reassemble the Clip trigger spring 9 and Clip trigger 8. Assemble the tip fitting according to instruction in 7.2.4.
Reassemble the tip ejector 10.

2-20 μ l, 20 μ l Fixed, 5-50 μ l 25 / 50 μ l Fixed

- Slide the spring 13, spring support 16 and tube 17 back onto the piston 12.
- Compress the spring 13 with your fingers by pressing the piston 12 and the spring support 16 against each other, and then slide the bigger O-ring 18, the smaller O-ring 19, the spring support 20 and spring 21 (smaller diameter against spring support 20) onto the piston.
- Hold the spring 13 compressed and carefully slide the entire assembly into the tip cone 11, and then release the spring.
- Put the spring 15 and support 14 on top of the tip cone and carefully insert the tip cone assembly to the handle. Attach the tip cone by turning it first clockwise tight by hand, then do the final tightening with the service tool.
- Reassemble the Clip trigger spring 9 and Clip trigger 8. Assemble the tip fitting according to instruction in 7.2.4.
Reassemble the tip ejector 10.

10-100 μ l, 20-200 μ l, 100 / 200 μ l Fixed, 30-300 μ l, 250 μ l Fixed

- Slide the spring 13, spring support 16 and O-ring 17 back onto the piston 12.
- Slide the entire assembly into the tip cone 11.
- Put the spring 15 and support 14 on top of the tip cone and carefully insert the tip cone assembly to the handle. Attach the tip cone by turning it first clockwise tight by hand, then do the final tightening with the service tool.
- Reassemble the Clip trigger spring 9 and Clip trigger 8. Assemble the tip fitting according to instruction in 7.2.4.
Reassemble the tip ejector 10.

100-1000 μ l, 500 / 1000 μ l Fixed

- Put the O-ring 17 and support ring 16 onto the tip cone 11.
- Slide the spring 13 onto the piston 12 and slide the entire assembly into the tip cone 11.
- Put the spring 15 and support 14 on top of the tip cone and carefully insert the tip cone assembly to the handle. Attach the tip cone by turning it first clockwise tight by hand, then do the final tightening with the service tool.
- Reassemble the tip ejector 11. Assemble the tip fitting according to instruction in 7.2.4.

7.2.4 Reassembly of tip fitting 5 and O-rings 5.1 and 5.2

- Make sure that the tip fitting has both o-rings 5.1 and 5.2 in place (Picture 8). Change o-rings during maintenance if needed. Place the tip fitting onto the star-shaped end of tool 3 so that the screw end is facing upwards. (Single channel pipettes 300 µl and smaller: Pull slightly the Clip trigger 8 backwards with the other hand). Insert the screw end into the cylinder and carefully screw in the tip fitting by turning the tool clockwise. Rotate the tool and tighten the tip fitting. Check that there is no gap between tip fitting and cylinder (Picture 13).

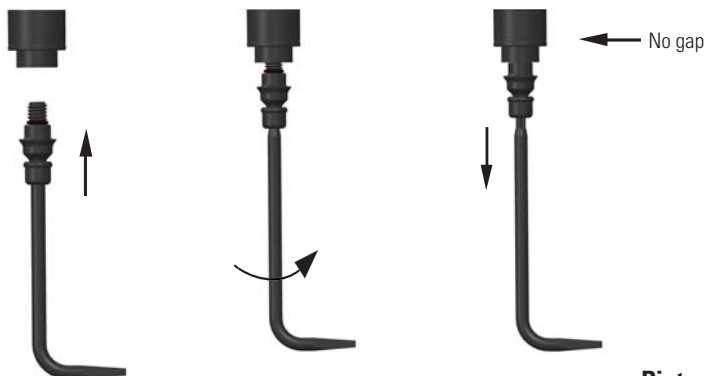

Picture 13



Be careful not to overtighten the tip fitting. This may damage the thread in the pipette.

7.2.5 Disassembly of multichannel pipettes

1. Remove the tip fittings (Picture 8).
To remove the tip fitting place the star-shaped end of tool 3 (picture 9) into the end of the fitting. Turn the tool counterclockwise to unscrew the tip fitting (picture 10).
Change tip fitting o-rings during maintenance if needed.
2. Press the tip ejector 4.1 down, whereupon it presses the tip ejector 23 down at the same time. Keep the ejector cover manually in the down position and let the tip ejector rise to the normal position, whereupon the parts snap apart revealing a slot 7. If needed, facilitate lightly by hand.
3. Keep the handle 4 still and insert the second end of the service tool 2 into the slot and turn clockwise to separate the handle and the module 6. from each other. Loosen until you can pull the parts apart.
4. Pull the holder spring 13 downwards and remove the two locking pieces 12. Finally, remove the holder spring carefully ensuring that the spring does not fly off.
5. Remove the two MCP adapter claws 44/45 and pull the MCP adapter 46 away. Remove the MCP spring base 43 by pulling upwards.
6. Remove the two screws 19 and pull the tip ejector 23 into the down position as shown in the picture on page 25.

7. While the tip ejector 23 is in the down position, open its upper end slightly on both sides and pull downwards. Remove the fastening spring 22. Remove the ejector link 24. Press the piston bar 16 beam into the down position. Finally unfasten the four screws 20/21 and the tip ejector. The ejector slide 25 and two springs 26 can be removed for maintenance. This does not belong to the regular long-term service, however.
8. Disengage the housing bottom 17 and piston bar 16 from each other. You can disengage the tip cone assembly 42 by pulling it away from the piston assembly 31. Disengage the piston assembly by pulling it out sideways from the piston bar as shown in the picture on page 25. Remove the piston spring 33.

7.2.6 Service instructions for multichannel pipette tip cones / cylinders

Volume: 1–10 µl

Disengage the tip cone cover 32 from the tip cone A (Picture 14) by easing it off with a flat-head screwdriver. The tip cone cover and the interior parts of the tip cone, the second support 35, the O-ring 37, the sealing casing 38, the dash spring 39, the spring support 40, and the O-ring 41, can all be removed in order by using the piston assembly 31 as shown in the picture. If some parts remain in the tip cone, they can be removed by turning the tip cone upside down and tapping it.

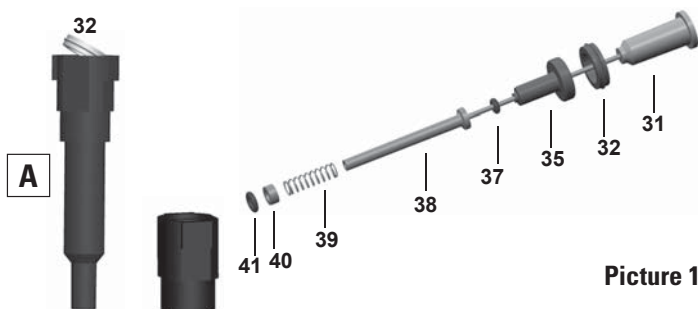

Picture 14

Volumes: 5–50 µl, 10–100 µl, and 30–300 µl

Disengage the tip cone cover 32 from the tip cone B (Picture 15) by easing it off with a flat-head screwdriver. The tip cone cover and the interior parts of the tip cone, the O-ring spring 34, the supporter ring 35, and the O-ring 36 (5–50µl/10–100µl: also O-ring 37), can all be removed in order by using the piston assembly 31 as shown in the picture. If some parts remain in the tip cone, they can be removed by turning the tip cone upside down and tapping it.

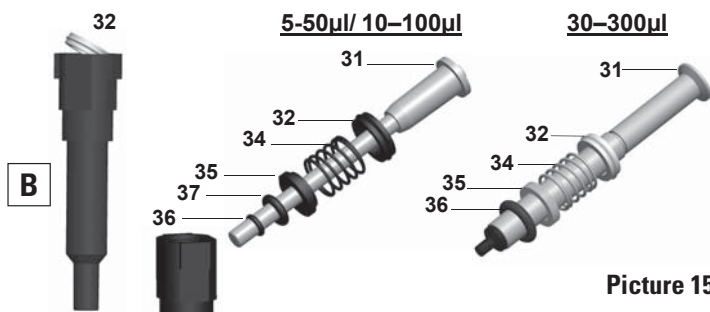

Picture 15

7.2.7 Cleaning and reassembling multichannel pipettes

See the cleaning instructions in Section 7.2.2 “Single channel pipettes”. Check the volume-specific reassembling of the piston assemblies starting on page 23. The pipette is assembled in the reverse order to disassembling. Note that the ejector link 24 must be in the down position simultaneously with the tip ejector 23 (page 25). Clean and lubricate the holder spring 13 before assembling.

NOTE!

To ensure even performance between all channels in a multichannel pipette, all tip cones have to be changed at the same time, if any of them needs to be changed. Don't mix tip cones of different packages, because one bag contains a matched set of tip cones. Place aligning studs to the same side when assembling the module (Picture 16).

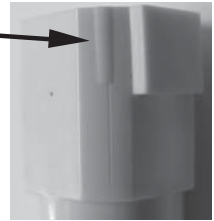

Picture 16

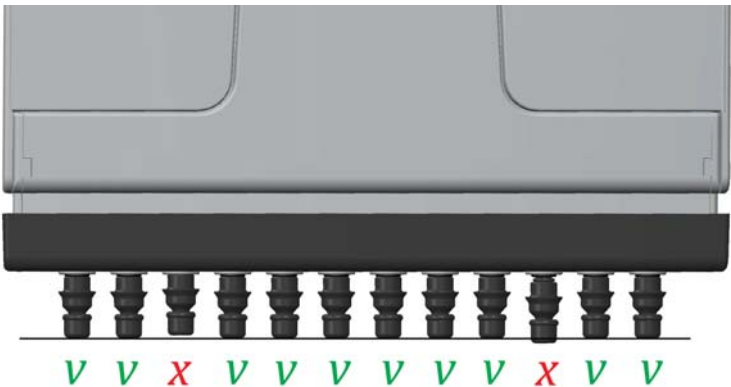

Picture 17



Make sure that the tip fittings are aligned in same level, adjust if necessary.

8. Sterilization

Before autoclaving, disassemble the tip fitting from the tip cone and autoclave them separately. After autoclaving, the tip cone and tip fitting must be cooled to room temperature for at least two hours. When reassembling, make sure that the tip cone and tip fitting are dry. We recommend checking the calibration after every sterilization cycle. The effectiveness of the autoclaving must be verified by the user.

8.1 Autoclavable parts:

Single and multichannel pipettes:

- Tip fitting (5)
- Tip fitting O-ring (5.1)

Single channel pipettes:

- Tip cone assembly (42)

Parts can be repeatedly autoclaved at 121°C (252°F) (2 ata) for 20 minutes.

9. Troubleshooting

The table below lists possible problems and their solutions.

Defect	Possible reason	Possible action
<i>Leakage</i>	<ul style="list-style-type: none"> • <i>Tip fitting incorrectly attached or loose</i> • <i>ClipTip clips are bent</i> • <i>Tip fitting o-ring damaged</i> • <i>Tip incorrectly attached</i> • <i>Foreign particles between the tip and the tip cone</i> • <i>Foreign particles between the piston, the O-ring and the cylinder</i> • <i>Insufficient amount of grease on the cylinder and the O-ring</i> • <i>O-ring damaged</i> 	<ul style="list-style-type: none"> ▶ <i>Re-attach/tighten the tip fitting or replace with new tip fitting(s) using the tool.</i> ▶ <i>Discard the tip.</i> ▶ <i>Change the O-ring.</i> ▶ <i>Attach firmly.</i> ▶ <i>Clean the tip cones and attach new tips.</i> ▶ <i>Clean and grease the O-ring and cylinder.</i> ▶ <i>Grease accordingly.</i> ▶ <i>Change the O-ring.</i>
<i>Inaccurate dispensing</i>	<ul style="list-style-type: none"> • <i>Incorrect operation</i> • <i>Tip incorrectly attached</i> • <i>Calibration altered; caused by misuse, for example</i> • <i>Wrong tip</i> • <i>Unsuitable calibration: a list of factors is presented in Section 4.1 "Calibration and adjustment"</i> • <i>Tip cone loose</i> • <i>Pipette not serviced</i> 	<ul style="list-style-type: none"> ▶ <i>Follow the instructions carefully.</i> ▶ <i>Attach firmly.</i> ▶ <i>Recalibrate according to the instructions.</i> ▶ <i>Use the correct tip.</i> ▶ <i>Readjust the pipette.</i> ▶ <i>Tighten the tip cone with the service tool.</i> ▶ <i>Perform pipette service.</i>
<i>Tip not ejecting</i>	<ul style="list-style-type: none"> • <i>Tip fitting not properly attached</i> • <i>Uneven tip ejecting with the multichannel</i> 	<ul style="list-style-type: none"> ▶ <i>Tighten the tip fitting.</i> ▶ <i>Tighten the tip fitting with the tool or replace the tip fitting set.</i>
<i>Piston jammed</i>	<ul style="list-style-type: none"> • <i>Pipette has been unused for a long period</i> • <i>Grease is removed while pipetting a highly volatile solvent repeatedly</i> 	<ul style="list-style-type: none"> ▶ <i>Remove the tip if attached. Press the plunger to the second stop and release several times to re-apply the grease.</i>
<i>Broken tip fitting</i>	<ul style="list-style-type: none"> • <i>Pipette dropped on the floor etc</i> 	<ul style="list-style-type: none"> ▶ <i>Use the tip fitting tool to remove the remaining part of the tip fitting. Place the flat head end of the tool 3 (picture 9) into the remaining part of the tip fitting and rotate counterclockwise to unscrew the remaining part. Assemble a new tip fitting.</i>
<i>Dispensing knob jammed to semi down position</i>	<ul style="list-style-type: none"> • <i>One sided force applied to the knob when adjusting the volume with one hand</i> 	<ul style="list-style-type: none"> ▶ <i>Pull up the knob and press down again to locked position</i>

10. Appendices

Appendix 1. Conversion table

Value of the conversion factor Z ($\mu\text{l}/\text{mg}$), as a function of temperature and pressure, for distilled water.

Temperature °C	Air pressure kPa						
	80	85	90	95	100	101.3	105
15.0	1.0017	1.0018	1.0019	1.0019	1.0020	1.0020	1.0020
15.5	1.0018	1.0019	1.0019	1.0020	1.0020	1.0020	1.0021
16.0	1.0019	1.0020	1.0020	1.0021	1.0021	1.0021	1.0022
16.5	1.0020	1.0020	1.0021	1.0021	1.0022	1.0022	1.0022
17.0	1.0021	1.0021	1.0022	1.0022	1.0023	1.0023	1.0023
17.5	1.0022	1.0022	1.0023	1.0023	1.0024	1.0024	1.0024
18.0	1.0022	1.0023	1.0023	1.0024	1.0025	1.0025	1.0025
18.5	1.0023	1.0024	1.0024	1.0025	1.0025	1.0026	1.0026
19.0	1.0024	1.0025	1.0025	1.0026	1.0026	1.0027	1.0027
19.5	1.0025	1.0026	1.0026	1.0027	1.0027	1.0028	1.0028
20.0	1.0026	1.0027	1.0027	1.0028	1.0028	1.0029	1.0029
20.5	1.0027	1.0028	1.0028	1.0029	1.0029	1.0030	1.0030
21.0	1.0028	1.0029	1.0029	1.0030	1.0031	1.0031	1.0031
21.5	1.0030	1.0030	1.0031	1.0031	1.0032	1.0032	1.0032
22.0	1.0031	1.0031	1.0032	1.0032	1.0033	1.0033	1.0033
22.5	1.0032	1.0032	1.0033	1.0033	1.0034	1.0034	1.0034
23.0	1.0033	1.0033	1.0034	1.0034	1.0035	1.0035	1.0036
23.5	1.0034	1.0035	1.0035	1.0036	1.0036	1.0036	1.0037
24.0	1.0035	1.0036	1.0036	1.0037	1.0037	1.0038	1.0038
24.5	1.0037	1.0037	1.0038	1.0038	1.0039	1.0039	1.0039
25.0	1.0038	1.0038	1.0039	1.0039	1.0040	1.0040	1.0040
25.5	1.0039	1.0040	1.0040	1.0041	1.0041	1.0041	1.0042
26.0	1.0040	1.0041	1.0041	1.0042	1.0042	1.0043	1.0043
26.5	1.0042	1.0042	1.0043	1.0043	1.0044	1.0044	1.0044
27.0	1.0043	1.0044	1.0044	1.0045	1.0045	1.0045	1.0046
27.5	1.0045	1.0045	1.0046	1.0046	1.0047	1.0047	1.0047
28.0	1.0046	1.0046	1.0047	1.0047	1.0048	1.0048	1.0048
28.5	1.0047	1.0048	1.0048	1.0049	1.0049	1.0050	1.0050
29.0	1.0049	1.0049	1.0050	1.0050	1.0051	1.0051	1.0051
29.5	1.0050	1.0051	1.0051	1.0052	1.0052	1.0052	1.0053
30.0	1.0052	1.0052	1.0053	1.0053	1.0054	1.0054	1.0054

Appendix 2. Manufacturer specification limits

Thermo Scientific F1-ClipTip Variable Volume Single Channel

Order No.	Range	Volume μ l	Inaccuracy		Imprecision		Compatible ClipTip
			μ l	%	SD μ l	CV%	
4641170	1–10 μ l	10	± 0.100	± 1.00	0.050	0.50	20
		1	± 0.025	± 2.50	0.020	2.00	
4641180	2–20 μ l	20	± 0.20	± 1.00	0.08	0.40	20
		2	± 0.06	± 3.00	0.05	2.50	
4641190	5–50 μ l	50	± 0.30	± 0.60	0.15	0.30	50
		5	± 0.15	± 3.00	0.125	2.50	
4641200	10–100 μ l	100	± 0.80	± 0.80	0.20	0.20	200
		10	± 0.30	± 3.00	0.10	1.00	
4641210	20–200 μ l	200	± 1.2	± 0.60	0.4	0.20	200
		20	± 0.36	± 1.80	0.14	0.70	
4641220	30–300 μ l	300	± 1.8	± 0.60	0.6	0.20	300
		30	± 0.45	± 1.50	0.18	0.60	
4641230	100–1000 μ l	1000	± 6.0	± 0.60	2.0	0.20	1000
		100	± 1.0	± 1.00	0.6	0.60	

Thermo Scientific F1-ClipTip Fixed Volume Single Channel

Order No.	Volume μ l	Inaccuracy		Imprecision		Compatible ClipTip
		μ l	%	SD μ l	CV%	
4651190	10	± 0.090	± 0.90	0.080	0.80	20
4651200	20	± 0.14	± 0.70	0.100	0.50	20
4651210	25	± 0.15	± 0.60	0.125	0.50	50
4651220	50	± 0.30	± 0.60	0.20	0.40	50
4651230	100	± 0.40	± 0.40	0.30	0.30	200
4651240	200	± 0.80	± 0.40	0.600	0.30	200
4651250	250	± 1.0	± 0.40	0.75	0.30	300
4651260	500	± 1.5	± 0.30	1.5	0.30	1000
4651270	1000	± 3.0	± 0.30	3.0	0.30	1000

Thermo Scientific F1-ClipTip Variable Volume Multichannel

Order No.	Range	Channel	Volume μ l	Inaccuracy		Imprecision		Compatible ClipTip
				μ l	%	SD μ l	CV%	
4661110	1–10 μ l	8	10	\pm 0.240	\pm 2.40	0.160	1.60	20
			1	\pm 0.120	\pm 12.00	0.080	8.00	
4661120	5–50 μ l	8	50	\pm 0.75	\pm 1.50	0.35	0.70	50
			5	\pm 0.25	\pm 5.00	0.10	2.00	
4661130	10–100 μ l	8	100	\pm 1.30	\pm 1.30	0.50	0.50	200
			10	\pm 0.50	\pm 5.00	0.20	2.00	
4661140	30–300 μ l	8	300	\pm 3.0	\pm 1.00	0.9	0.30	300
			30	\pm 1.5	\pm 5.00	0.6	2.00	
4661150	1–10 μ l	12	10	\pm 0.240	\pm 2.40	0.160	1.60	20
			1	\pm 0.120	\pm 12.00	0.080	8.00	
4661160	5–50 μ l	12	50	\pm 0.75	\pm 1.50	0.35	0.70	50
			5	\pm 0.25	\pm 5.00	0.10	2.00	
4661170	10–100 μ l	12	100	\pm 1.30	\pm 1.30	0.50	0.50	200
			10	\pm 0.50	\pm 5.00	0.20	2.00	
4661180	30–300 μ l	12	300	\pm 3.0	\pm 1.00	0.9	0.30	300
			30	\pm 1.5	\pm 5.00	0.6	2.00	

Appendix 3. ISO8655 calibration specifications

Thermo Scientific F1-ClipTip specifications according to ISO8655 standard.

Thermo Scientific F1-ClipTip Variable Volume Single Channel

Range	Volume μ l	Inaccuracy		Imprecision		Compatible ClipTip	Color code
		μ l	%	SD μ l	CV%		
1–10 μ l	10	± 0.120	± 1.2	0.080	0.8	20	pink
	1	± 0.120	± 12	0.080	8.0		
2–20 μ l	20	± 0.20	± 1.0	0.10	0.5	20	pink
	2	± 0.20	± 10.0	0.10	5.0		
5–50 μ l	50	± 0.50	± 1.0	0.20	0.4	50	violet
	5	± 0.50	± 10	0.20	4.0		
10–100 μ l	100	± 0.80	± 0.8	0.30	0.3	200	yellow
	10	± 0.80	± 8.0	0.30	3.0		
20–200 μ l	200	± 1.60	± 0.8	0.60	0.3	200	yellow
	20	± 1.60	± 8.0	0.60	3.0		
30–300 μ l	300	± 4.0	± 1.3	1.5	0.5	300	orange
	30	± 4.0	± 13	1.5	5.0		
100–1000 μ l	1000	± 8.0	± 0.8	3.0	0.3	1000	blue
	100	± 8.0	± 8.0	3.0	3.0		

Thermo Scientific F1-ClipTip Fixed Volume Single Channel

Fixed Volume μ l	Inaccuracy μ l	%	Imprecision SD μ l	CV%	Compatible ClipTip
10	± 0.120	± 1.20	0.080	0.80	20
20	± 0.20	± 1.00	0.10	0.50	20
25	± 0.50	± 2.00	0.20	0.80	50
50	± 0.50	± 1.00	0.20	0.40	50
100	± 0.80	± 0.80	0.30	0.30	200
200	± 1.60	± 0.80	0.60	0.30	200
250	± 4.00	± 1.60	1.50	0.60	300
500	± 4.00	± 0.80	1.50	0.30	1000
1000	± 8.00	± 0.80	3.00	0.30	1000

Thermo Scientific F1-ClipTip Variable Volume Multichannel

Range	Channel	Volume μ l	Inaccuracy		Imprecision		Compatible ClipTip	Color code
			μ l	%	SD μ l	CV%		
1–10 μ l	8, 12	10	± 0.24	± 2.4	0.16	1.6	20	pink
		1	± 0.24	± 24	0.16	16		
5–50 μ l	8, 12	50	± 1.0	± 2.0	0.4	0.8	50	violet
		5	± 1.0	± 20	0.4	8.0		
10–100 μ l	8, 12	100	± 0.80	± 0.8	0.30	0.3	200	yellow
		10	± 0.80	± 8.0	0.30	3.0		
30–300 μ l	8, 12	300	± 8.0	± 2.7	3.0	1.0	300	orange
		30	± 8.0	± 26.7	3.0	10.0		

Appendix 4. Assembly and spare parts

* Available as a spare part. See model specific order numbers on page 27.

1062800
Service and
adjustment tool

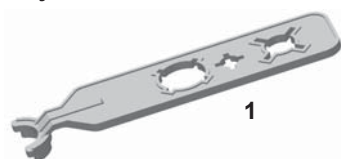

1062930
Multichannel service tool

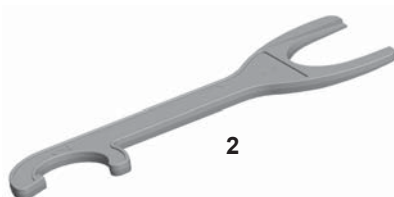

0300070 Tip fitting tool



* 5. Tip fitting



* 42. Tip cone assembly

* 50. Module



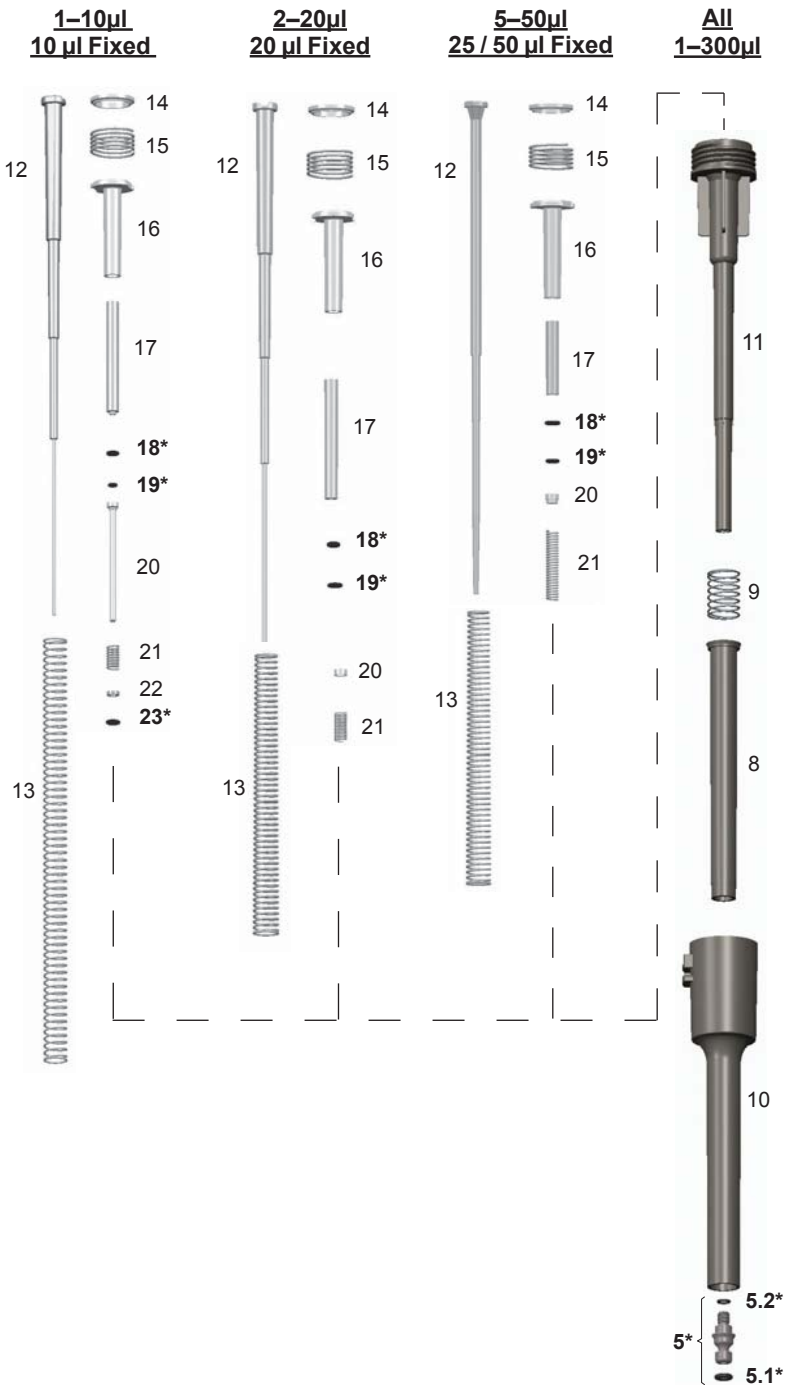

10-100µl **20-200µl** **30-300µl** **All** **100-1000µl**
100 / 200 µl Fixed **250µl Fixed** **1-300µl** **500 / 1000 µl Fixed**

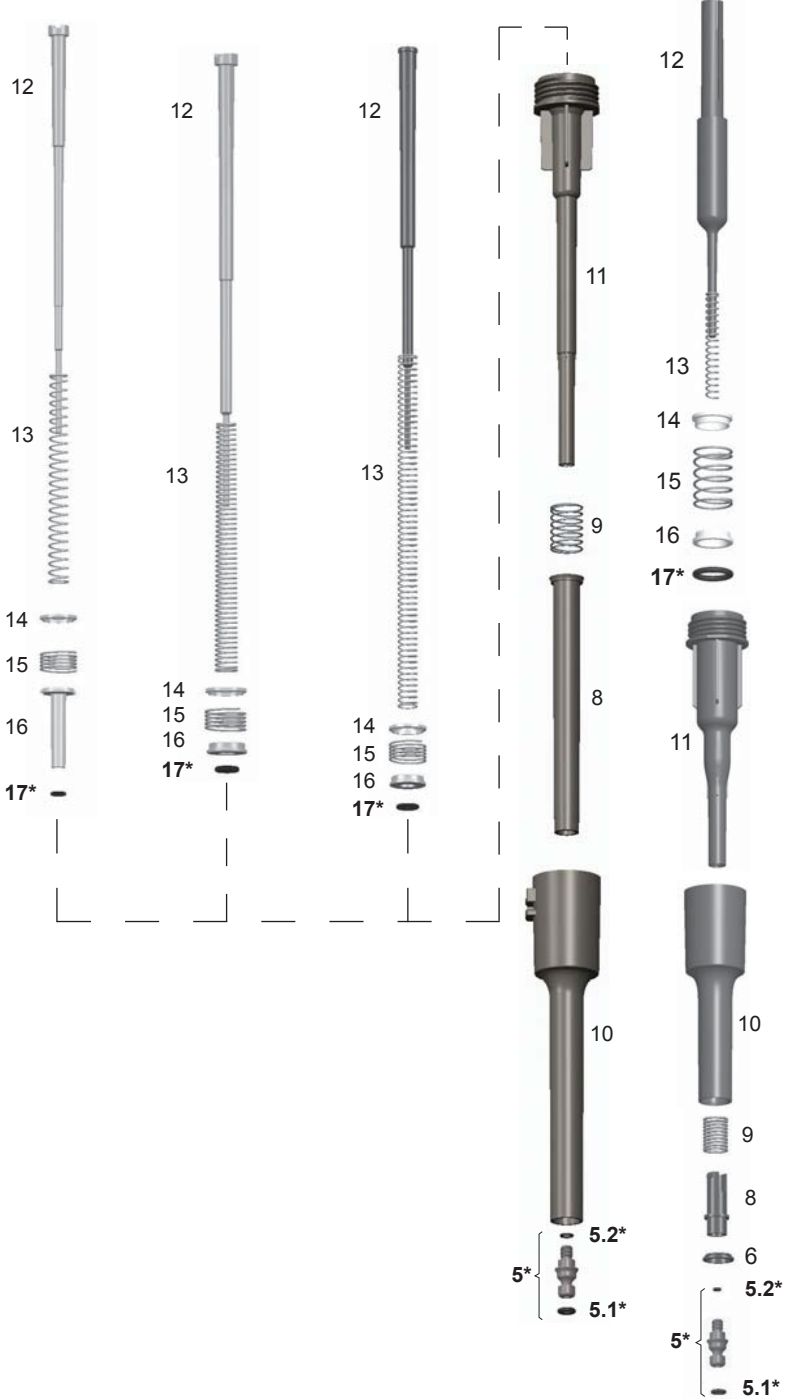

* 50

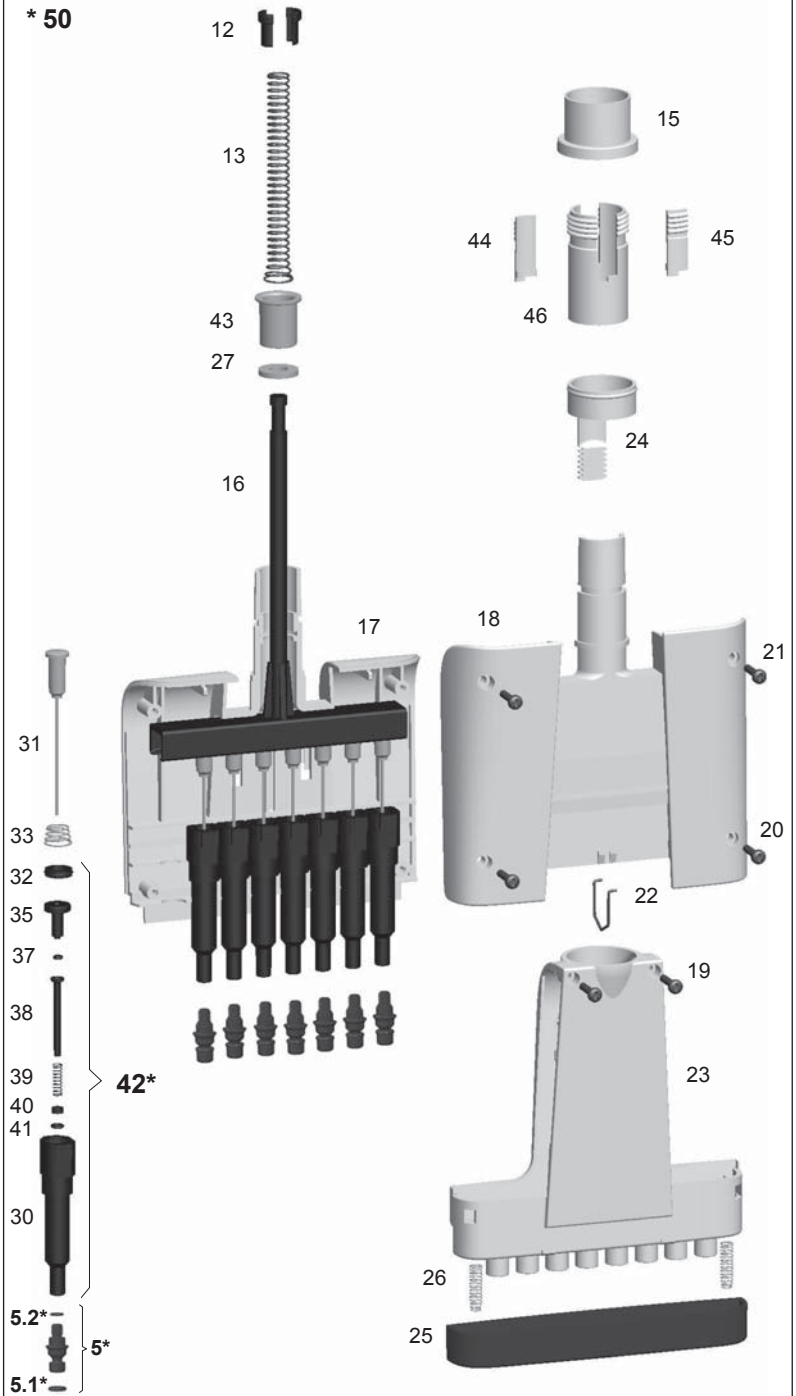

50*

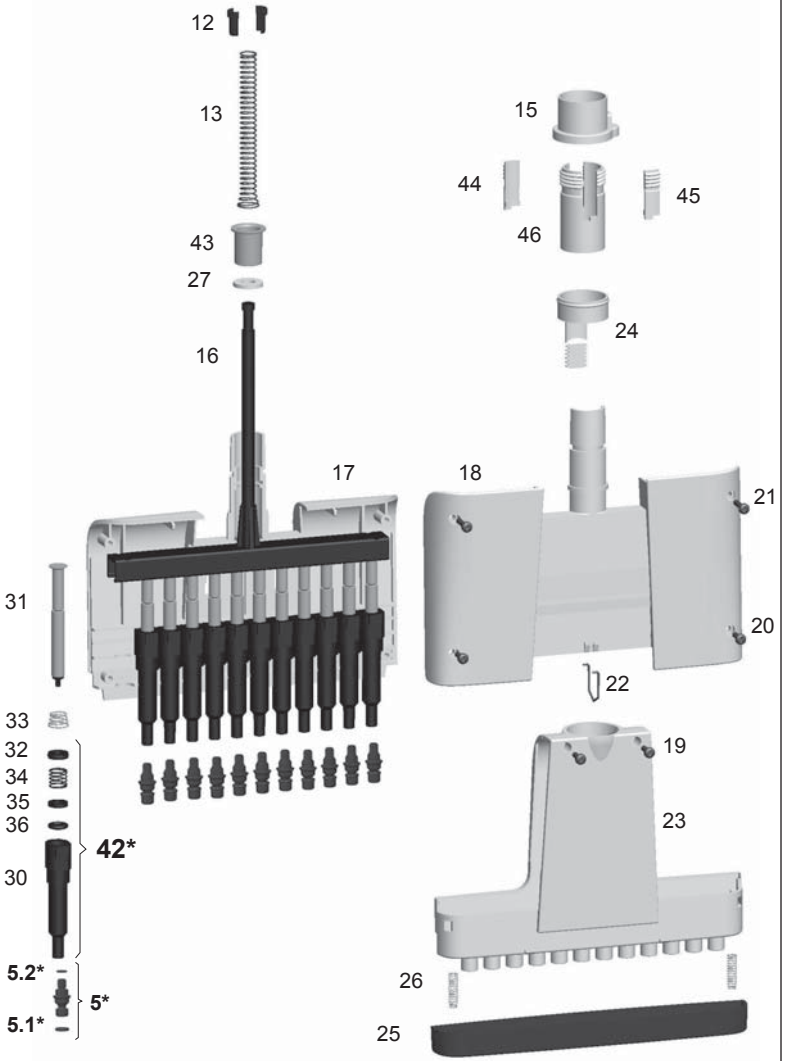

F1-ClipTip single channel and multichannel spare part order numbers

Single Channel

1–10µl / 10µl Fixed

- 5. 2216160 4 pcs
- 5.1. 2214930 3 pcs
- 5.2. 1033430
- 18. 1030380
- 19. 1030060
- 23. 1030170
- 42. 2216080N

2–20µl / 20µl Fixed

- 5. 2216160 4 pcs
- 5.1. 2214930 3 pcs
- 5.2. 1033430
- 18. 1030380
- 19. 1033110
- 42. 2216090N

5–50µl / 25µl / 50µl Fixed

- 5. 2216160 4 pcs
- 5.1. 2214930 3 pcs
- 5.2. 1033430
- 18. 1030500
- 19. 1039060
- 42. 2216100N

10–100µl

- 5. 2216160 4 pcs
- 5.1. 2214930 3 pcs
- 5.2. 1033430
- 17. 1030510
- 42. 2216110N

20–200µl / 100µl / 200µl Fixed

- 5. 2216160 4 pcs
- 5.1. 2214930 3 pcs
- 5.2. 1033430
- 17. 1030160
- 42. 2216120N

30–300µl / 250µl Fixed

- 5. 2216160 4 pcs
- 5.1. 2214930 3 pcs
- 5.2. 1033430
- 17. 1033330
- 42. 2216130N

100–1000µl **500µl / 1000µl Fixed**

- 5. 2216190 4 pcs
- 5.1. 2215540 3 pcs
- 5.2. 1033430
- 17. 1030020
- 42. 2216220N

Multichannel

8-ch / 12-ch

- 5. 2216170 8 pcs
- 5. 2216180 12 pcs
- 5.1. 2214920 12 pcs
- 5.2. 1033430
- 42. 2214390 1–10µl 12 pcs
- 42. 2214400 5–50µl 12 pcs
- 42. 2214410 10–100µl 12 pcs
- 42. 2214420 30–300µl 12 pcs

8-ch

- 50. 2213620N 1–10µl
- 50. 2213630N 5–50µl
- 50. 2213640N 10–100µl
- 50. 2213650N 30–300µl

12-ch

- 50. 2213660N 1–10µl
- 50. 2213670N 5–50µl
- 50. 2213680N 10–100µl
- 50. 2213690N 30–300µl

Appendix 5. ClipTip ordering information

Thermo Scientific ClipTip racked and sterile tips

Code	ClipTip	Volume	Qty
94410210	ClipTip 20	20 µl	10x96/rack
94410213	ClipTip 20, sterile	20 µl	10x96/rack
94410250	ClipTip 50	50 µl	10x96/rack
94410253	ClipTip 50, sterile	50 µl	10x96/rack
94410310	ClipTip 200	200 µl	10x96/rack
94410313	ClipTip 200, sterile	200 µl	10x96/rack
94410510	ClipTip 300	300 µl	10x96/rack
94410513	ClipTip 300, sterile	300 µl	10x96/rack
94410710	ClipTip 1000	1000 µl	8x96/rack
94410713	ClipTip 1000, sterile	1000 µl	8x96/rack

Thermo Scientific ClipTip reload inserts

Code	ClipTip	Volume	Qty
94410217	ClipTip 20	20 µl	10x96/insert
94410218	ClipTip 20, sterile	20 µl	10x96/insert
94410257	ClipTip 50	50 µl	10x96/insert
94410258	ClipTip 50, sterile	50 µl	10x96/insert
94410317	ClipTip 200	200 µl	10x96/insert
94410318	ClipTip 200, sterile	200 µl	10x96/insert
94410517	ClipTip 300	300 µl	10x96/insert
94410518	ClipTip 300, sterile	300 µl	10x96/insert
94410717	ClipTip 1000	1000 µl	8x96/insert
94410718	ClipTip 1000, sterile	1000 µl	8x96/insert

Thermo Scientific ClipTip filter tips , sterile

Code	ClipTip	Volume	Qty
94420213	ClipTip Filter 20	20 µl	10x96/rack
94420253	ClipTip Filter 50	50 µl	10x96/rack
94420313	ClipTip Filter 200	200 µl	10x96/rack
94420513	ClipTip Filter 300	300 µl	10x96/rack
94420713	ClipTip Filter 1000	1000 µl	8x96/rack

All ClipTip tips are certified to be free from RNase, DNase, DNA, ATP and endotoxins.

Appendix 6. F1-ClipTip and ClipTip compatibility table

	Non-filter tips					Filter tips				
	ClipTip 20	ClipTip 50	ClipTip 200	ClipTip 300	ClipTip 1000	ClipTip Filter 20	ClipTip Filter 50	ClipTip Filter 200	ClipTip Filter 300	ClipTip Filter 1000
F1-ClipTip 1–10µl	x					x				
F1-ClipTip 2–20µl	x					x				
F1-ClipTip 5–50µl		x					x			
F1-ClipTip 10–100µl			x					x		
F1-ClipTip 20–200µl			x					x		
F1-ClipTip 30–300µl				x					x	
F1-ClipTip 100–1000µl					x					x
F1-ClipTip 10µl fixed volume	x					x				
F1-ClipTip 20µl fixed volume	x					x				
F1-ClipTip 25µl fixed volume		x					x			
F1-ClipTip 50µl fixed volume		x					x			
F1-ClipTip 100µl fixed volume			x					x		
F1-ClipTip 200µl fixed volume			x					x		
F1-ClipTip 250µl fixed volume				x					x	
F1-ClipTip 500µl fixed volume					x					x
F1-ClipTip 1000µl fixed volume					x					x
F1-ClipTip 8-ch 1–10µl	x					x				
F1-ClipTip 8-ch 5–50µl		x					x			
F1-ClipTip 8-ch 10–100µl			x					x		
F1-ClipTip 8-ch 30–300µl				x					x	
F1-ClipTip 12-ch 1–10µl	x					x				
F1-ClipTip 12-ch 5–50µl		x					x			
F1-ClipTip 12-ch 10–100µl			x					x		
F1-ClipTip 12-ch 30–300µl				x					x	

Appendix 7. Pipette accessories



**Multichannel stand
#9420390**



**F-stand
#9420400**



**Reagent reservoir
100 ml #95128085**

**Reagent reservoir
25 ml #95128093**

**Reagent reservoir
25 ml divided #951228095**

info.pipettes@thermofisher.com
www.thermofisher.com

thermofisher.com

© 2016 Thermo Fisher Scientific Inc. All rights reserved. All trademarks are the property of Thermo Fisher Scientific Inc. and its subsidiaries. Specifications, terms and pricing are subject to change. Not all products are available in all countries. Please consult your local sales representative for details.

Thermo Fisher Scientific
Ratastie 2, P.O.Box 100
FI-01621 Vantaa
Finland

1508990-01

Thermo
SCIENTIFIC
Part of Thermo Fisher Scientific